

# robel

17667

**ROUPEIRO CONCEPT 1.8**

**CONCEPT CLOSET 1.8**

**CONCEPTO ARMARIO 1.8**

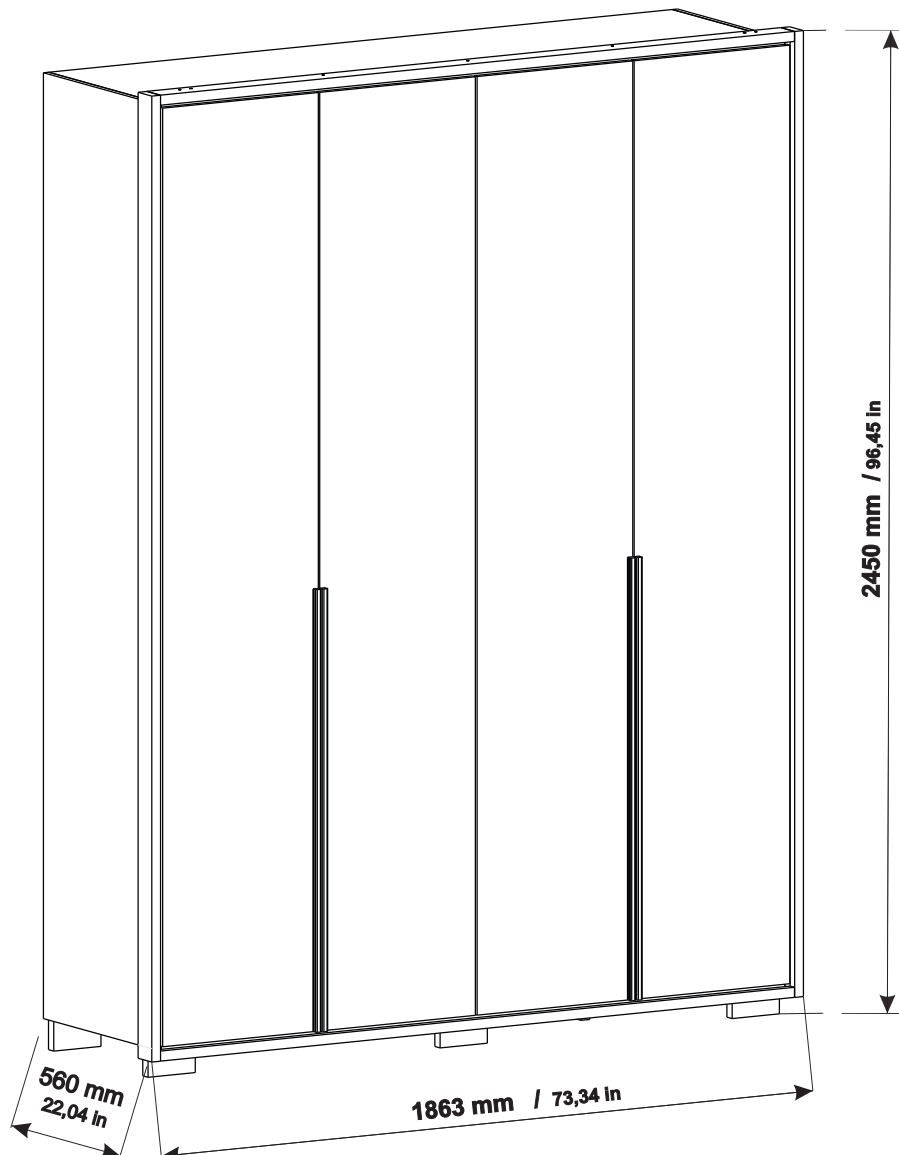

[www.robel.com.br](http://www.robel.com.br)  
[17 3203 0400](tel:1732030400)

# ACESSÓRIOS

HARDWARES - HERRAJES

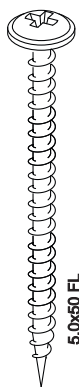

PARAFUSO  
SCREW  
TORNILLO

**A**  
14x

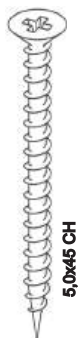

PARAFUSO  
SCREW  
TORNILLO

**B**  
14x

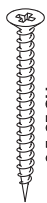

PARAFUSO  
SCREW  
TORNILLO

**C**  
12x

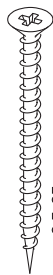

PARAFUSO  
SCREW  
TORNILLO

**D**  
10x



PARAFUSO  
SCREW  
TORNILLO

**E**  
150x



CAVILHA  
DOWEL  
TARUGO

**F**  
72x

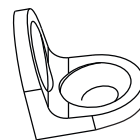

CANTONEIRA  
CORNER  
ESQUINA

**G**  
6x

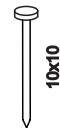

PREGO  
NAIL  
CLAVO

**H**  
110x

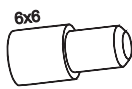

SUPORTE PRAT. MÓVEL  
MOBILE SHELF SUPPORT  
SOPORTE DE ESTANTE MÓVIL

**I**  
16x



PINO MINIFIX  
MINIFIX BOLT  
TORNILLO MINIFIX

**J**  
30x

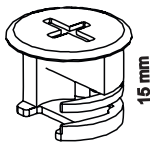

CASTANHA MINIFIX  
MINIFIX CAM  
CAJA MINIFIX

**K**  
40x

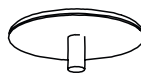

TAMPA DO GIROFIX  
GIROFIX COVER  
FUNDA GIROFIX

**L**  
30x

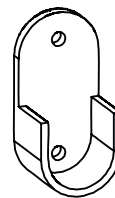

SUPORTE CABIDEIRO  
ROD END SUPPORT  
SOPORTE TUBO OVALHADO

**M**  
6x

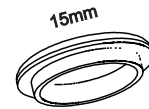

TAPA FURO  
HOLE COVER  
TAPA CON ORIFÍCIO

**N**  
10x

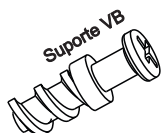

PARAFUSO  
SCREW  
TORNILLO

**O**  
10x

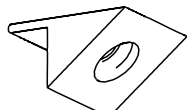

SUPORTE FUNDO DE GAVETA  
WEDGE BRACKETS SUPPOT  
SOPORTE DE CUÑA

**P**  
12x

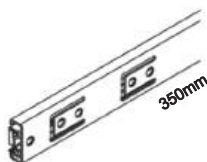

CORREDIÇA TELESCÓPICA  
TELESCOPIC SLIDE  
CORREDIZA TELESCÓPICA

**Q**  
03x (pares)

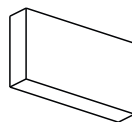

PÉ  
LEG  
PIE

**R**  
7x

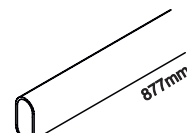

TUBO OBLONGO  
OBLONG ROD

**S**  
1x

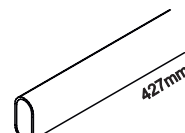

TUBO OBLONGO  
OBLONG ROD

**T**  
2x

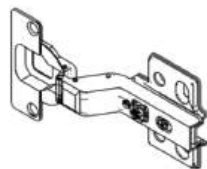

DOBRADIÇA  
HINGE  
BISAGRA

**U**  
16x

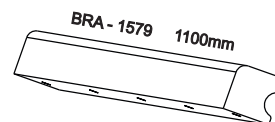

PUXADOR  
HANDLE KIT  
MANIJA

**V**  
4x



PARAFUSO  
SCREW  
TORNILLO

**W**  
20x

**É utilizado 5 parafusos 'W' em cada porta de madeira, variando a quantidade total para cada configuração.**

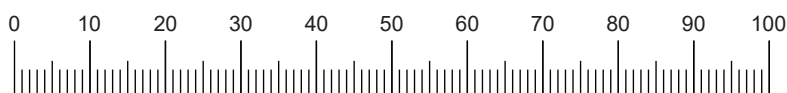

# CAPACIDADE DE CARGA

LOAD CAPACITY - CAPACIDAD DE CARGA

A CAPACIDADE DE CARGA INDICADA É DISTRIBUÍDA NAS ÁREAS DEMONSTRADAS.

THE INDICATED LOAD CAPACITY IS DISTRIBUTED IN THE SHOWN AREAS.

LA CAPACIDAD DE CARGA INDICADA ES DISTRIBUIDA EN ZONAS DEMONSTRADAS.

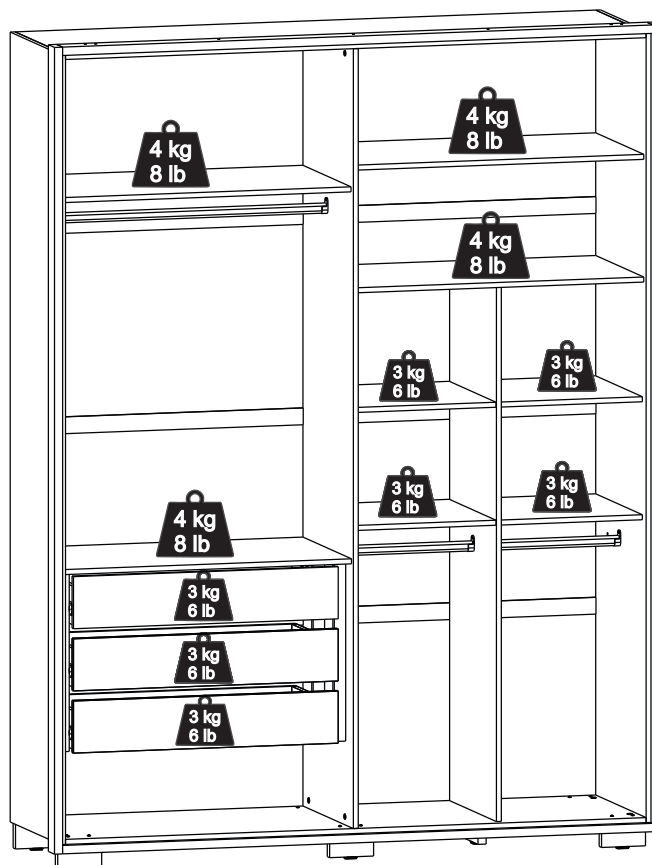

## TERMOS DE GARANTIA

**O PROJETO, INSTALAÇÃO E A MONTAGEM NA RESIDÊNCIA DO CONSUMIDOR NÃO É DE RESPONSABILIDADE DA ROBEL (GRUPO CANEIRA).**

DESIGN, INSTALLATION AND ASSEMBLY AT THE CONSUMER'S HOME IS NOT THE RESPONSIBILITY OF THE ROBEL (GRUPO CANEIRA).

EL DISEÑO, LA INSTALACIÓN Y EL MONTAJE EN EL DOMICILIO DEL CONSUMIDOR NO ES RESPONSABILIDAD DEL ROBEL (GRUPO CANEIRA).

**O MONTADOR DEVE SEGUIR EXATAMENTE AS INSTRUÇÕES DO MANUAL DE MONTAGEM DE CADA PRODUTO.**

THE ASSEMBLER MUST FOLLOW THE INSTRUCTIONS IN THE ASSEMBLY MANUAL FOR EACH PRODUCT EXACTLY.

EL MONTADOR DEBE SEGUIR EXACTAMENTE LAS INSTRUCCIONES DEL MANUAL DE MONTAJE DE CADA PRODUCTO.

## EXCLUSÃO DA GARANTIA

THIS TERM EXCLUDES FROM ITS GUARANTEE

ESTE TÉRMINO EXCLUYE DE SU GARANTÍA

**O PRESENTE TERMO EXCLUI DE SUA GARANTIA:**

THIS TERM EXCLUDES FROM ITS GUARANTEE

ESTE TÉRMINO EXCLUYE DE SU GARANTÍA

**- DANOS CAUSADOS EM CONSEQÜÊNCIA DE ACIDENTES, MAU USO, MANUSEIO OU DESLOCAMENTO INCORRETO DOS PRODUTOS;**

- DAMAGE CAUSED AS A RESULT OF ACCIDENTS, MISUSE, INCORRECT HANDLING OR MOVEMENT OF THE PRODUCTS;

- LOS DAÑOS CAUSADOS COMO CONSECUENCIA DE ACCIDENTES, USO INDEBIDO, MANIPULACIÓN INCORRECTA O DESPLAZAMIENTO DE LOS PRODUCTOS;

**- DANOS CAUSADOS POR MONTAGEM INADEQUADA;**

- DAMAGE CAUSED BY IMPROPER ASSEMBLY;

- DAÑOS CAUSADOS POR UN MONTAJE INCORRECTO;

**- DANOS EM DECORRÊNCIA DE AGENTES EXTERNOS (INUNDAÇÕES, INCENDIOS E ETC);**

- DAMAGE CAUSED BY EXTERNAL AGENTS (FLOODS, FIRES, ETC.);

- DAÑOS CAUSADOS POR AGENTES EXTERNOS (INUNDACIONES, INCENDIOS, ETC.);

**- DEFEITOS ORIUNDOS DE UMIDADES EXCESSIVAS;**

- DEFECTS CAUSED BY EXCESSIVE HUMIDITY;

- DEFECTOS CAUSADOS POR UN EXCESO DE HUMEDAD.

**CONSERVANDO O SEU MÓVEL / MANTENIENDO SU MOBILIARIO / MAINTAINING YOUR FURNITURE**

**LIMPEZA DO MÓVEL / LIMPIANDO SU MOBILIARIO / CLEANING**

Na remoção da poeira utilizar flanela limpa e levemente umedecida, em seguida flanela seca para remoção da umidade.

Para limpiar el polvo utiliza una flanela limpia y humedecida y después una flanela seca para quitar la humedad.

To remove dust use a clean flannel slightly moistened and afterwards a dry flannel to remove the humidity.

**RECOMENDAÇÕES DE USO / RECOMENDACIONES DE USO / USE RECOMMENDATIONS**

**Não expor a luz solar e locais úmidos.**

No exponga a la luz solar y lugares húmedos.

Do not expose to sun light and humid places.

**Não encostar o móvel na parede para evitar transmissão de umidade.**

No apoye el mobiliario en la pared evitar la transmisión de humedad.

Do not lean the furniture in the wall to avoid humidity transmission.

## PORTUGUÊS

## ENGLISH

## ESPAÑOL

- 1 BASE
- 2 TAMPO
- 4 LATERAL ESQUERDA
- 6 DIVISÓRIA ESQUERDA
- 7 PRATELEIRA
- 8 PRATELEIRA CENTRAL
- 9 DIVISÓRIA CENTRAL
- 10 PRATELEIRA MÓVEL
- 11 DISTÂNCIADOR GAVETA
- 12 FRENTE GAVETA
- 13 FUNDO GAVETA
- 14 CONTRA FUNDO
- 15 PINÁZIO
- 16 MOLDURA LATERAL
- 17 MOLDURA SUPERIOR/INFERIOR
- 18 LATERAL GAVETA
- 19 FUNDO TRASEIRO
- 21 PORTA LISA DIREITA
- 22 PORTA LISA ESQUERDA
- 23 PORTA FRISADA DIREITA
- 24 PORTA FRISADA ESQUERDA
- 25 PORTA PUXADOR CAVA DIREITA
- 26 PORTA PUXADOR CAVA INTERNA ESQUERDA
- 27 PORTA PUXADOR CAVA FRISADA DIREITA
- 28 PORTA PUXADOR CAVA INTERNA FRISADA ESQUERDA
- 29 LATERAL DIREITA

- 1 BASIS
- 1 TOP
- 1 LEFT SIDE
- 1 LEFT PARTITION
- 3 SHELF
- 1 CENTER SHELF
- 1 CENTRAL PARTITION
- 4 MOBILE SHELF
- 4 DRAWER DISTANCER
- 3 DRAWER FRONT
- 3 DRAWER BOTTOM
- 3 BACKGROUND
- 6 PINAZ
- 2 SIDE FRAME
- 2 TOP/BOTTOM FRAME
- 6 DRAWER SIDE
- 4 BACK BOTTOM
- 1 SMOOTH RIGHT DOOR
- 1 SMOOTH LEFT DOOR
- 1 RIGHT BEADED DOOR
- 1 LEFT BEADED DOOR
- 1 CAVA HANDLE DOOR RIGHT
- 1 LEFT INTERNAL CAVA HANDLE DOOR
- 1 RIGHT BEADED CAVA HANDLE DOOR
- 1 DOOR HANDLE INNER CAVA BEADED LEFT
- 1 RIGHT SIDE

- BASE
- ARRIBA
- LADO IZQUIERDO
- PARTICIÓN IZQUIERDA
- ESTANTE
- ESTANTE CENTRAL
- PARTICIÓN CENTRAL
- ESTANTE MÓVIL
- DISTANCIA CAJÓN
- FRENTE DEL CAJÓN
- FONDO DEL CAJÓN
- FONDO
- PINAZ
- MARCO LATERAL
- MARCO SUPERIOR/INFERIOR
- LADO DEL CAJÓN
- ATRÁS ABAJO
- PUERTA DERECHA LISA
- PUERTA IZQUIERDA LISA
- PUERTA CON CUENTAS DERECHA
- PUERTA DE CUENTAS IZQUIERDA
- MANIJA CAVA PUERTA DERECHA
- MANIJA PUERTA CAVA INTERIOR IZQUIERDA
- TIRADOR PUERTA CAVA PERLAS DERECHA
- MANIJA DE PUERTA INTERIOR CAVA CON CUENTAS IZQUIERDA
- LADO DERECHO

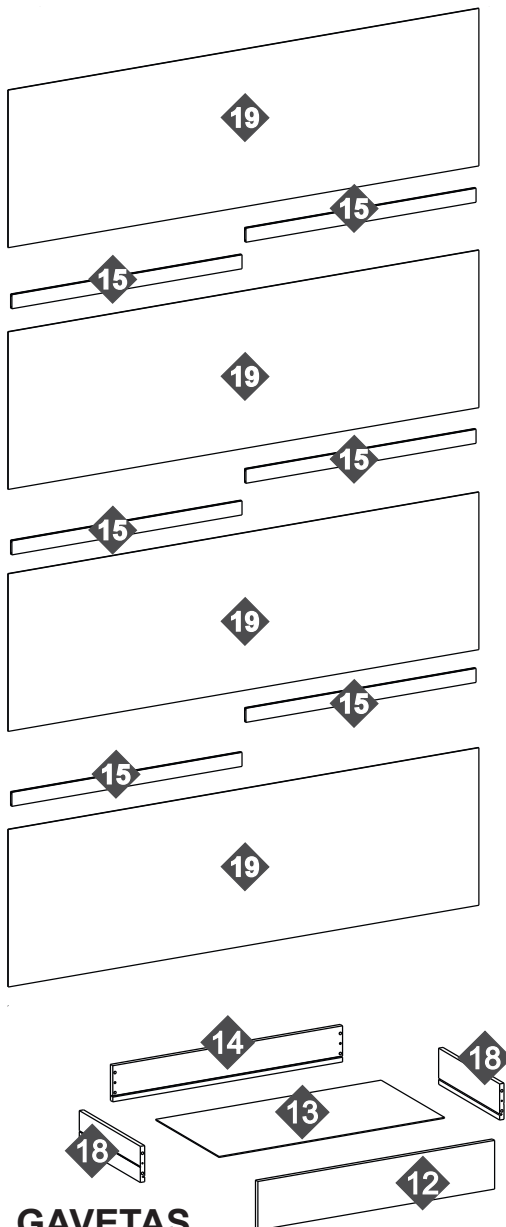

**GAVETAS  
(3x)**

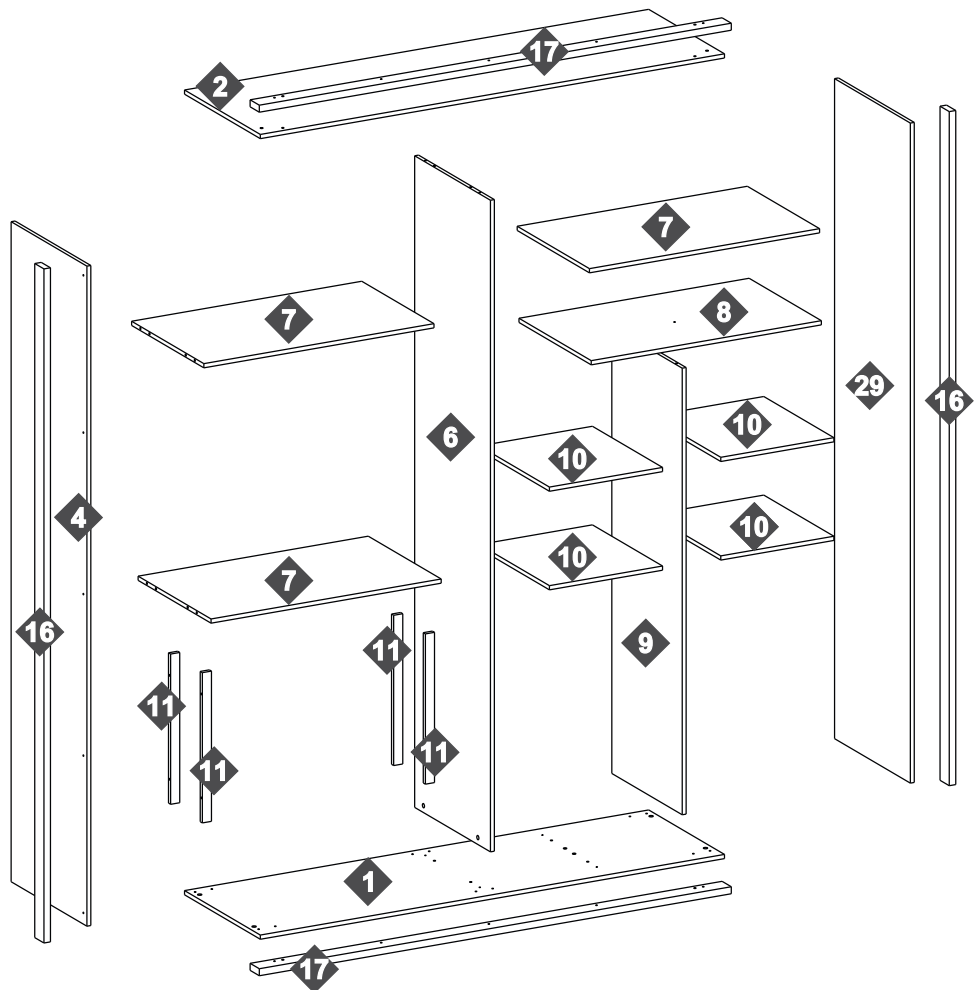

# MONTAGEM

ASSEMBLY - MONTAJE

## \* EXCELÊNCIA EM ROUPEIROS DE QUALIDADE.

\* EXCELLENCE IN QUALITY CLOSETS.

\* EXCELENCIA EN ARMARIOS DE CALIDAD.

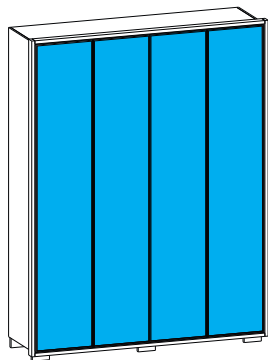

PORTAS COM ESPELHO /  
OU COM VIDRO REFLECTA

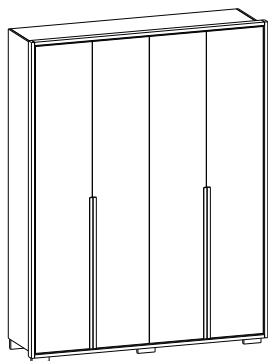

PORTAS LISAS COM  
PUXADORES EXTERNOS  
(BRASM)

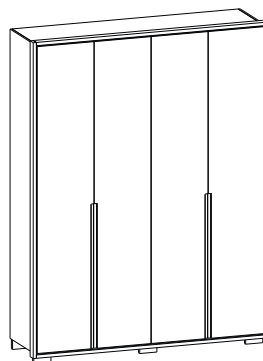

PORTAS LISAS COM  
PUXADORES INTERNOS  
(CAVA)

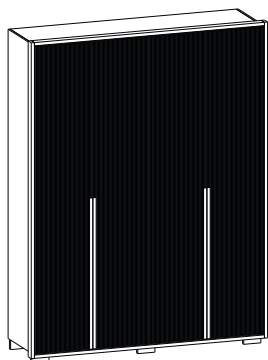

PORTAS FRISADAS COM  
PUXADORES EXTERNOS.

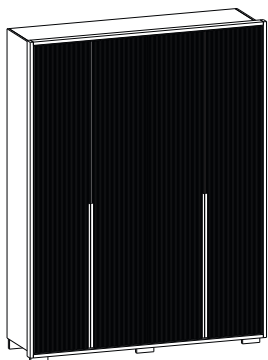

PORTAS FRISADAS COM  
PUXADORES INTERNOS  
(CAVA).

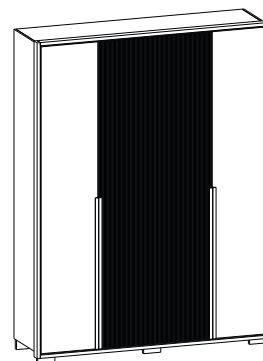

PORTAS LISAS E FRISADAS  
COM PUXADORES  
EXTERNOS.

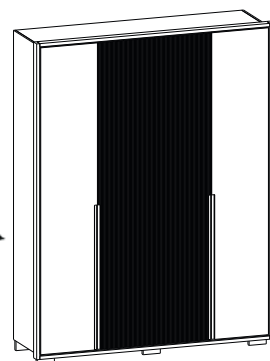

PORTAS LISAS E FRISADAS  
COM PUXADORES INTERNOS  
(CAVA).

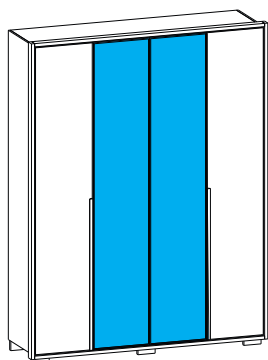

PORTAS LISAS E COM  
ESPELHO / OU COM VIDRO  
REFLECTA COM PUXADORES  
EXTERNOS (BRA)

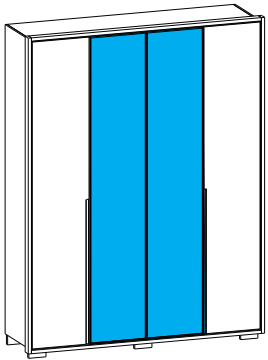

PORTAS LISAS E COM  
ESPELHO / OU COM VIDRO  
REFLECTA COM PUXADORES  
INTERNOS (CAVA).

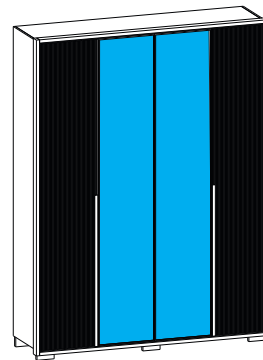

PORTAS FRISADAS COM  
ESPELHO / OU VIDROS  
REFLECTA COM  
PUXADORES EXTERNOS.

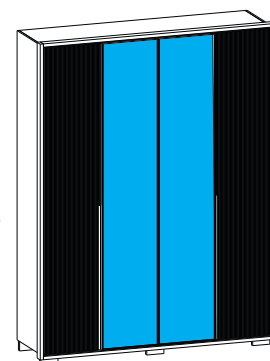

PORTAS FRISADAS COM  
ESPELHO / OU VIDROS  
REFLECTA COM PUXADORES  
INTERNOS (CAVA).

- 21 Porta Lisa Direita (Pux. Externo BRA)
- 22 Porta Lisa Esquerda (Pux. Externo BRA)
- 23 Porta Frisada Direita (Pux. Externo BRA)
- 24 Porta Frisada Esquerda (Pux. Externo BRA)
- 25 Porta Puxador Interno Cava Direita
- 26 Porta Puxador Interno Cava Esquerda
- 27 Porta Frisada Puxador Interno Cava Direita
- 28 Porta Frisada Puxador Interno Cava Esquerda

# PRÉ-MONTAGEM

PRE ASSEMBLY - PRÉ-MONTAJE

## IMPORTANTE

ATTENTION - IMPORTANTE

A MONTAGEM DEVE SER REALIZADA POR UM PROFISSIONAL DE MONTAGEM.

ASSEMBLY MUST BE CARRIED OUT BY AN ASSEMBLY PROFESSIONAL.

EL MONTAJE DEBE SER HECHO POR UN MONTADOR DE MUEBLES.

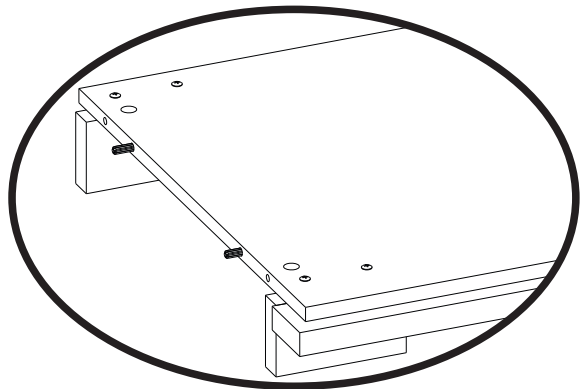
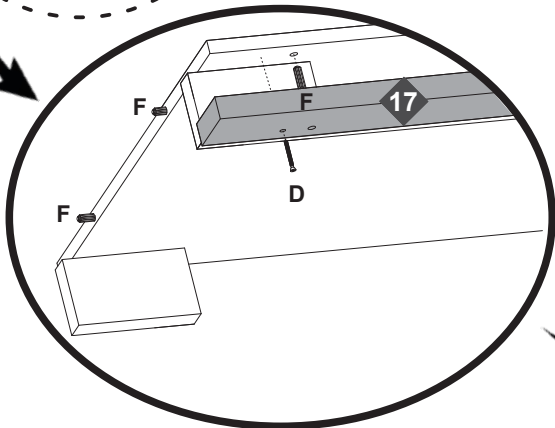
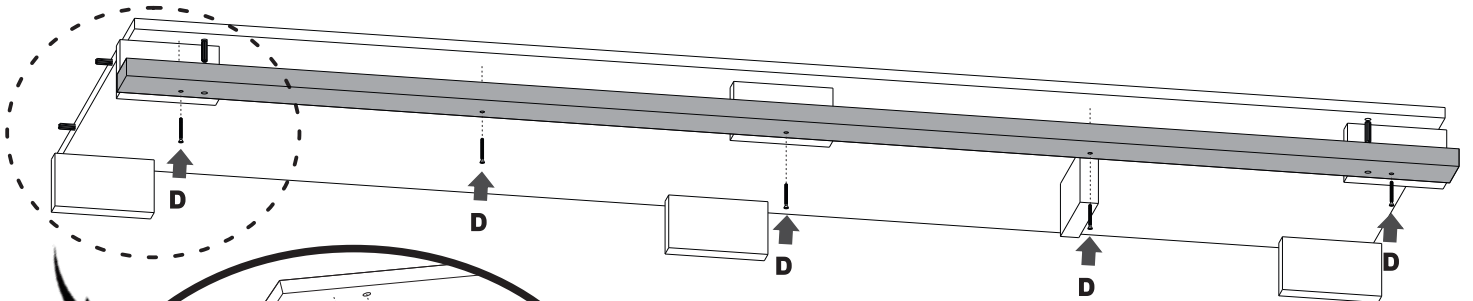
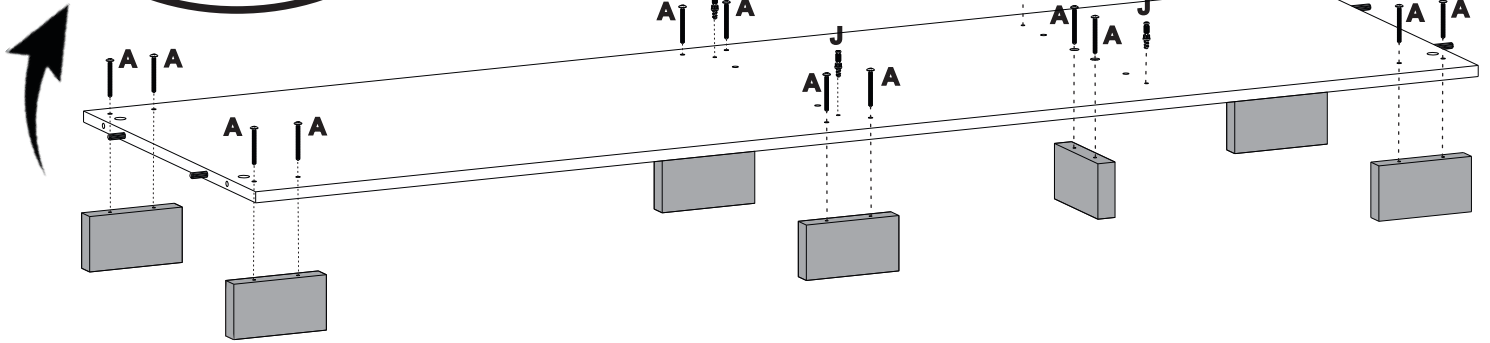
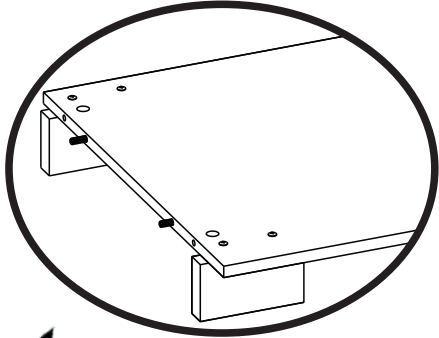
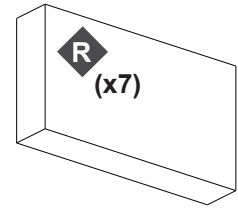
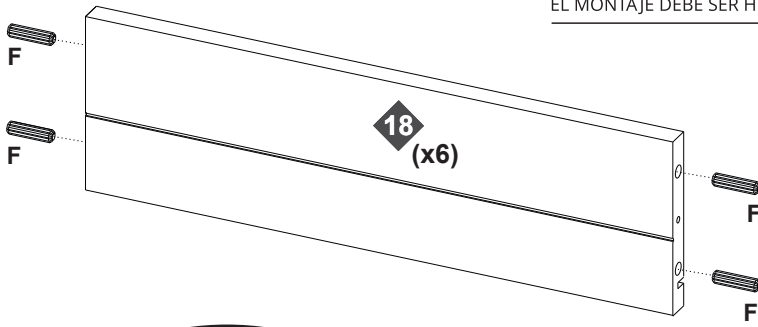

## INSTRUÇÕES

INSTRUCTIONS - INSTRUCCIONES

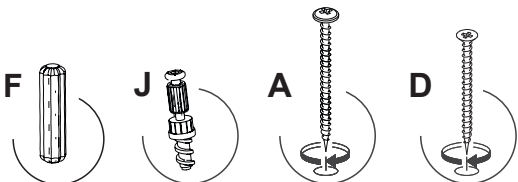

# PRÉ-MONTAGEM

PRE ASSEMBLY - PRÉ-MONTAJE

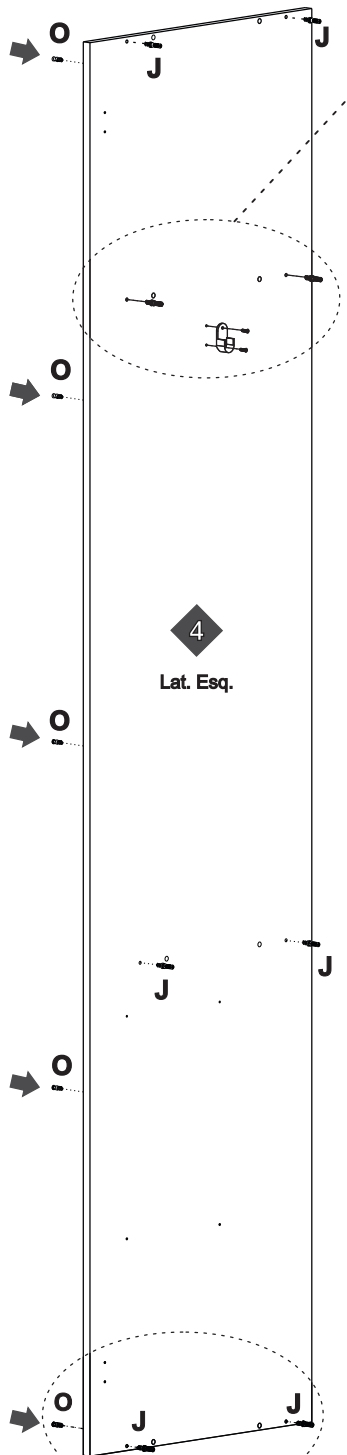
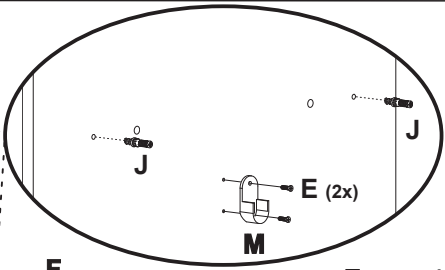

4  
Lat. Esq.

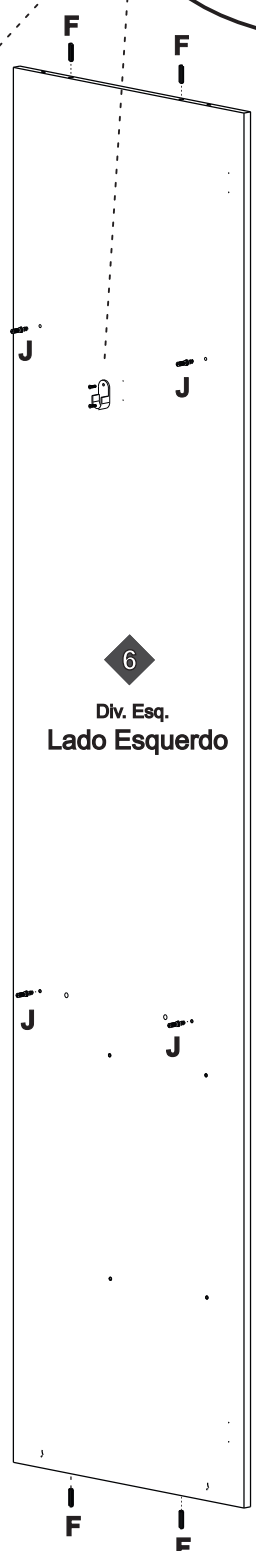

6  
Div. Esq.  
Lado Esquerdo



6  
Div. Esq.  
Lado Direito  
M  
E (2x)

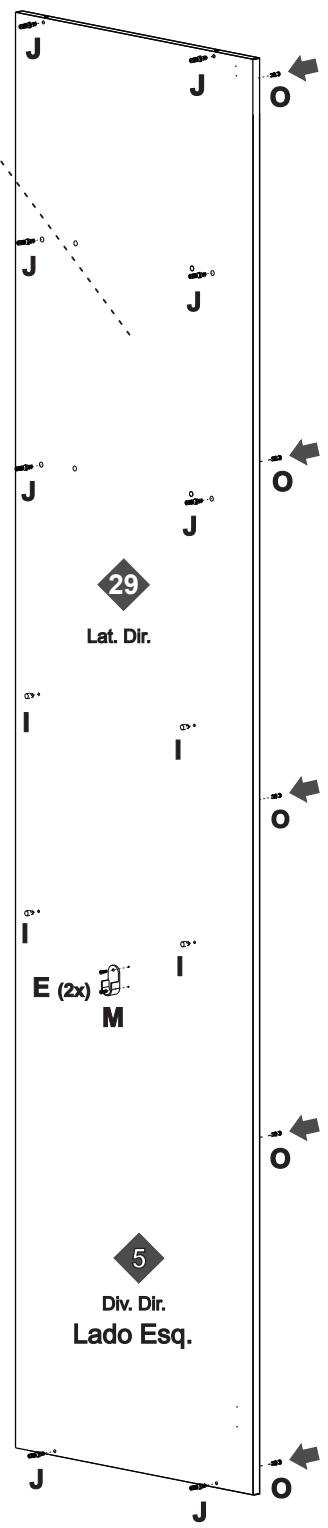

29  
Lat. Dir.

5  
Div. Dir.  
Lado Esq.

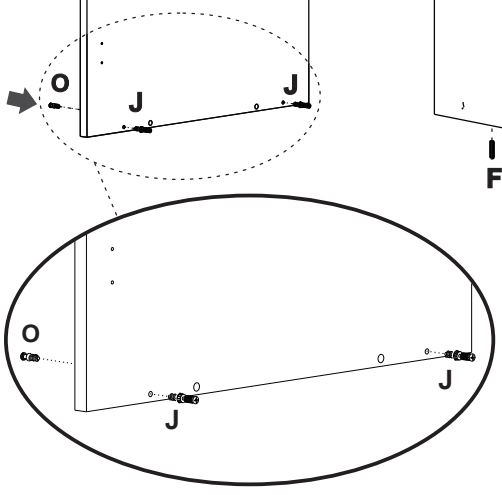

## INSTRUÇÕES

INSTRUCTIONS - INSTRUCCIONES

F

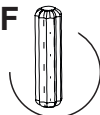

E



M



J

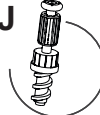

O

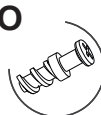

I

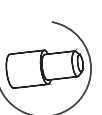

# PRÉ-MONTAGEM

PRE ASSEMBLY - PRÉ-MONTAJE

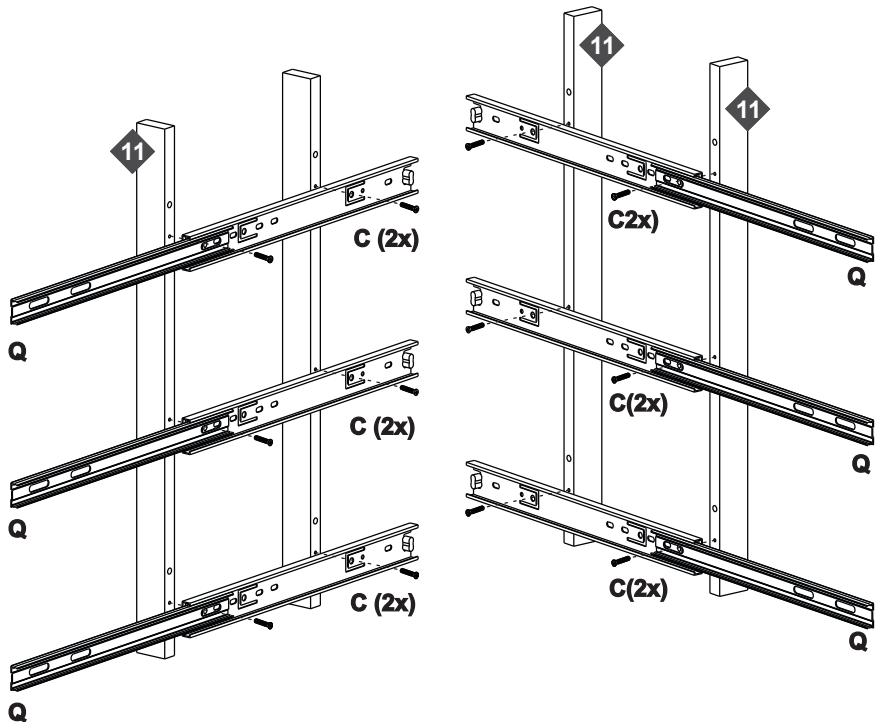
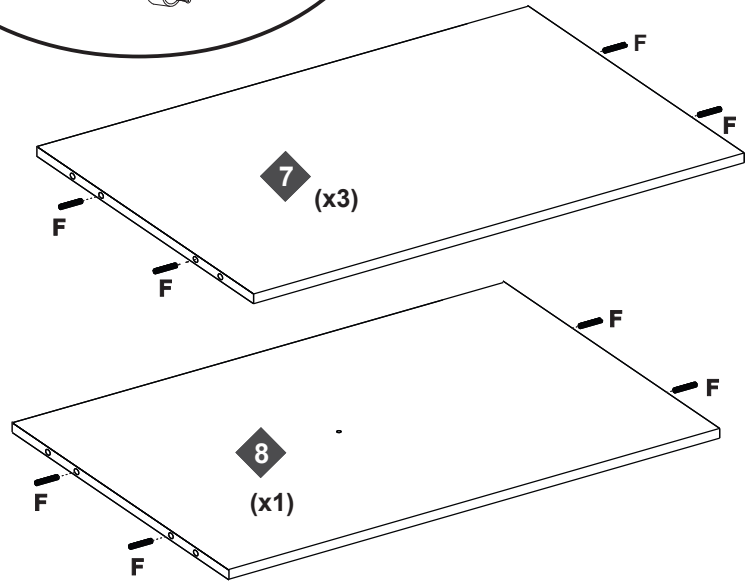
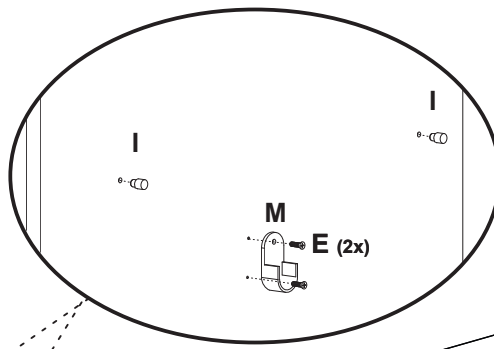
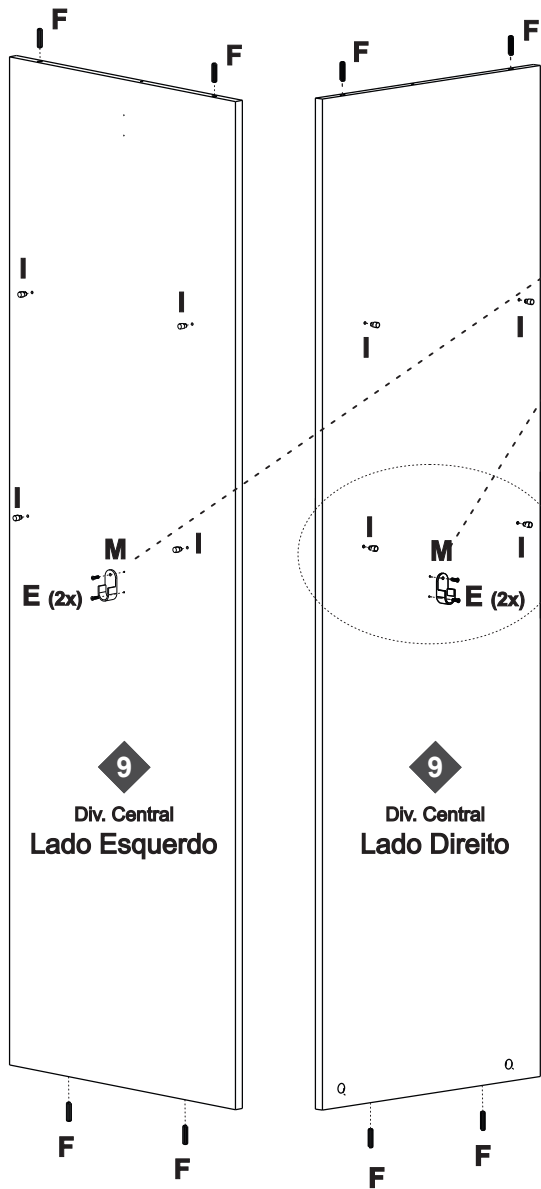

## INSTRUÇÕES

INSTRUCTIONS - INSTRUCCIONES

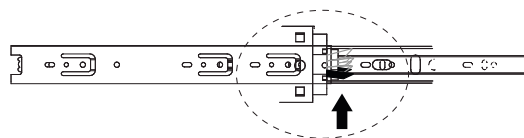
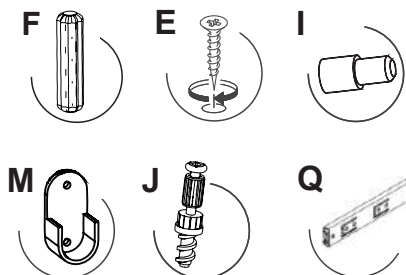

Para separar o apliche é necessário movimentar o apliche de plástico que encontra-se no verso da mesma.  
Mova o apliche para cima, segure e puxe a parte removível da corredeira.

To separate the slider, it is necessary to move the plastic insert on the it's back.  
Move the applique up, hold and pull the removable part of the slider.

Para separar la corredera es necesario movl la pieza de plástico que se encuentra en la parte posterior de la misma.

Mover la pieza de plástico, mantenga y tire la parte móvil de la corredera.



# PRÉ-MONTAGEM

PRE ASSEMBLY - PRÉ-MONTAJE

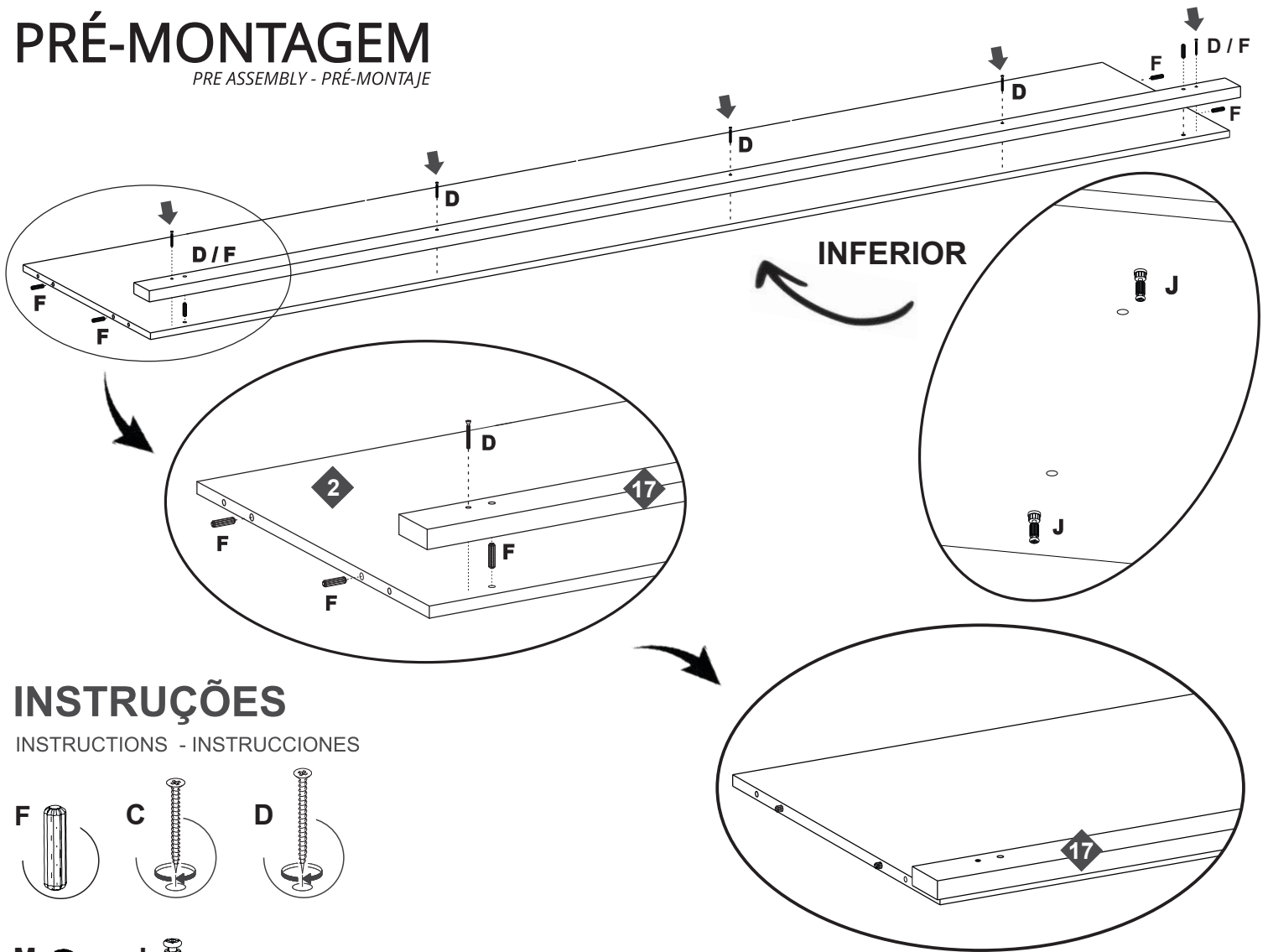

## INSTRUÇÕES

INSTRUCTIONS - INSTRUCCIONES

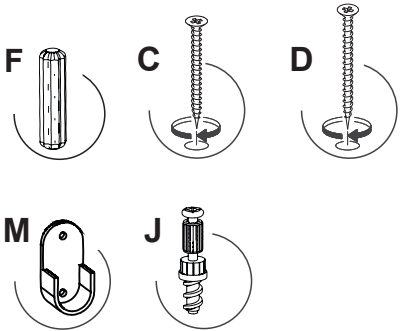

## MONTAGEM

ASSEMBLY - MONTAJE

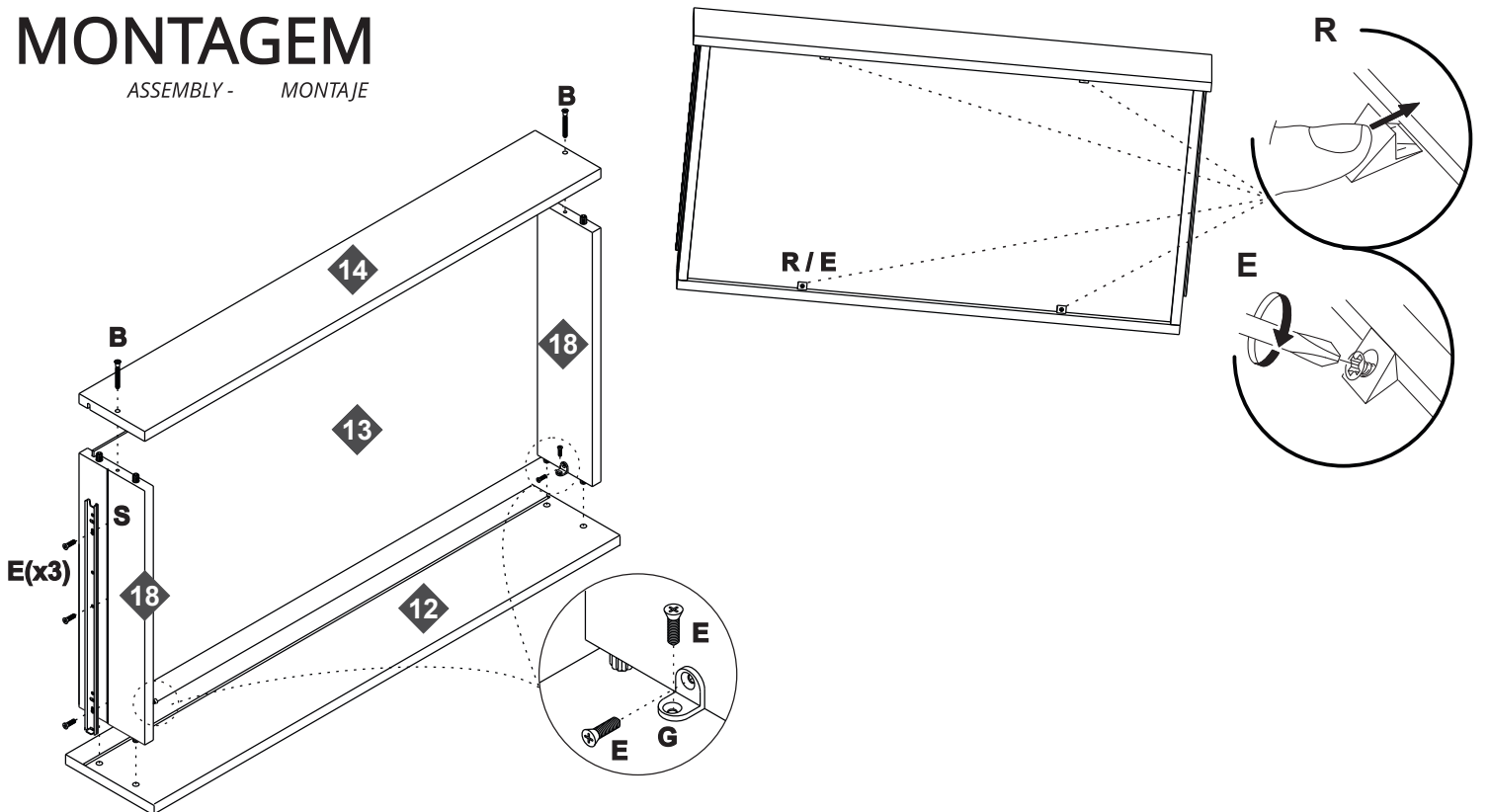

# MONTAGEM

ASSEMBLY - MONTAJE

## INSTRUÇÕES

INSTRUCTIONS - INSTRUCCIONES

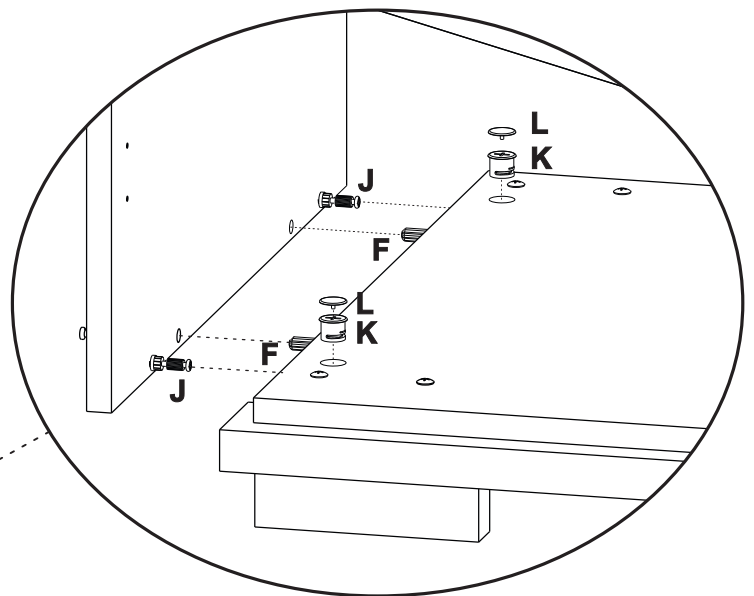
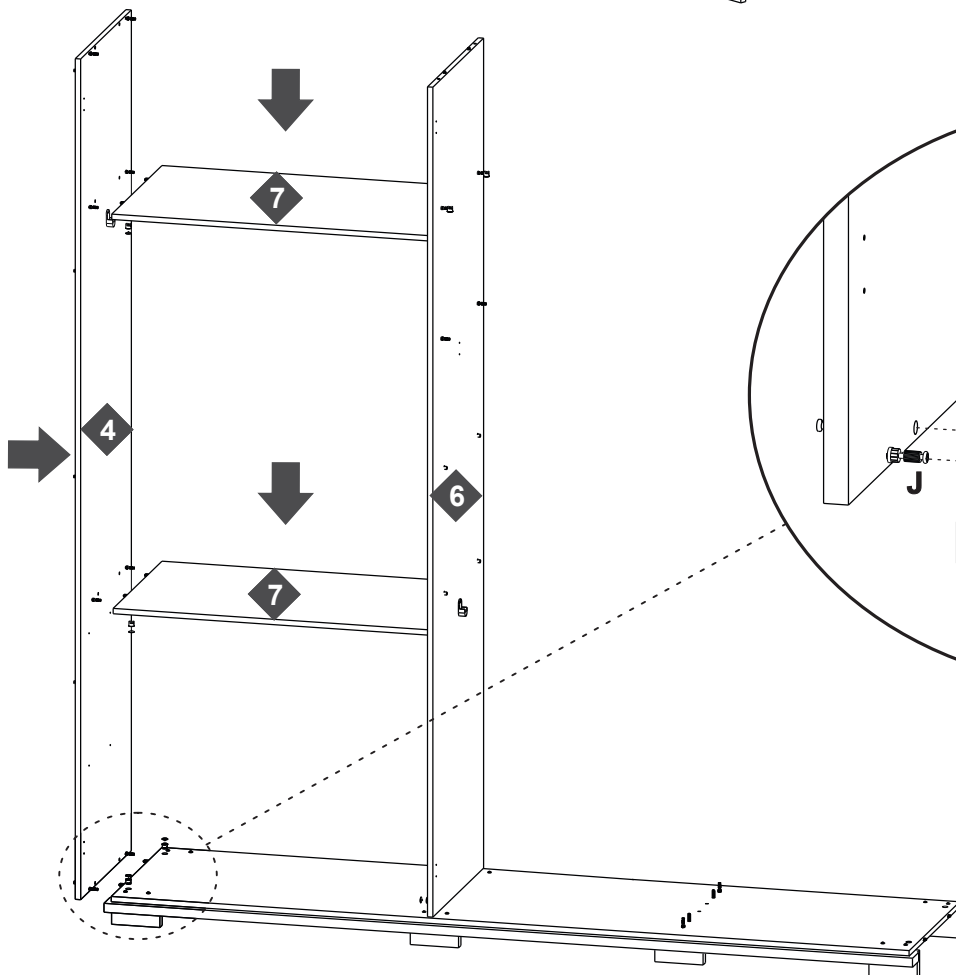
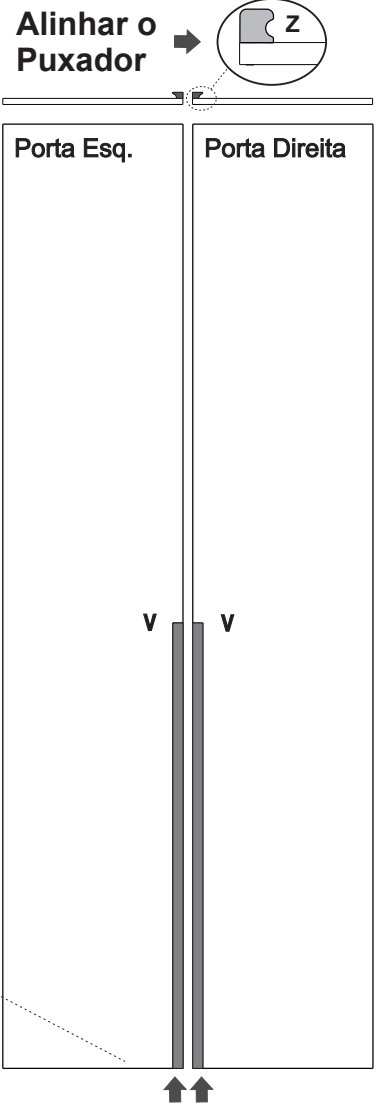
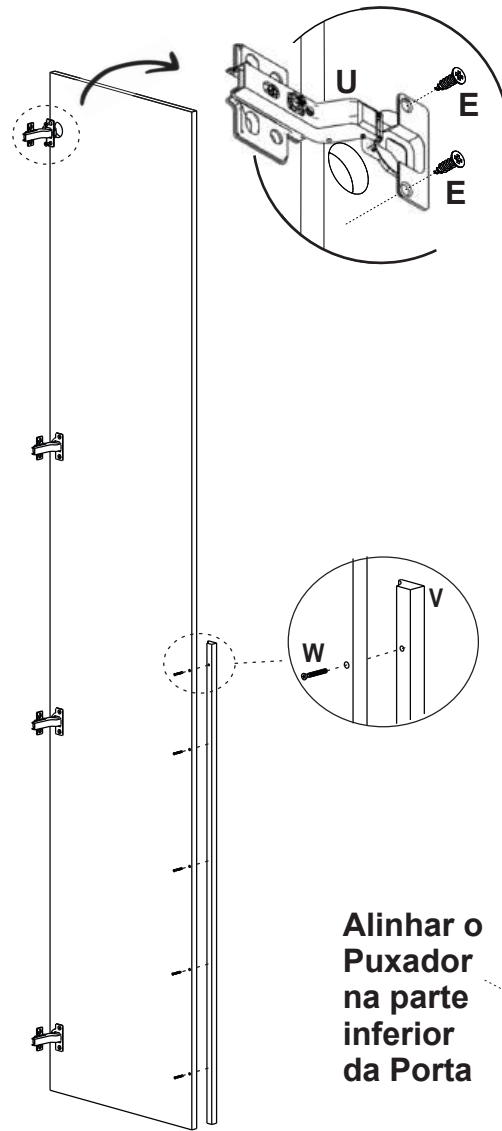
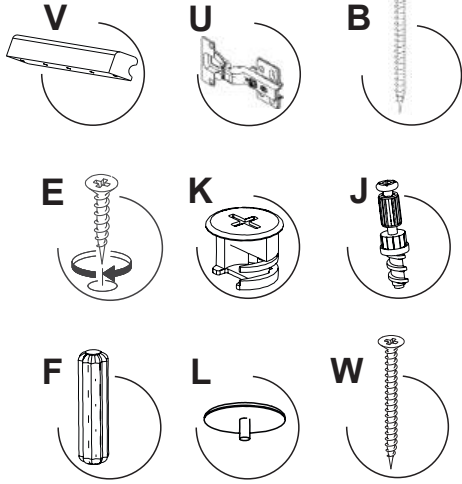

# MONTAGEM

ASSEMBLY - MONTAJE

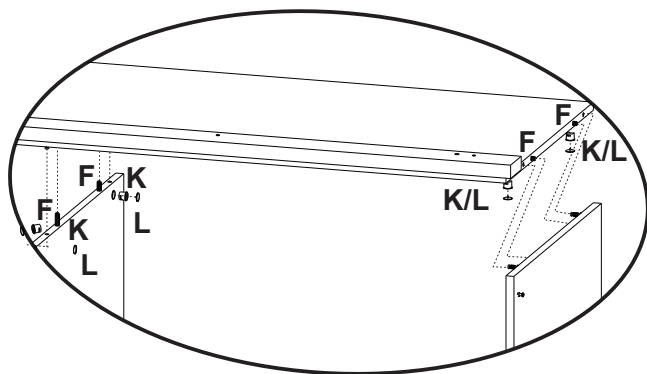
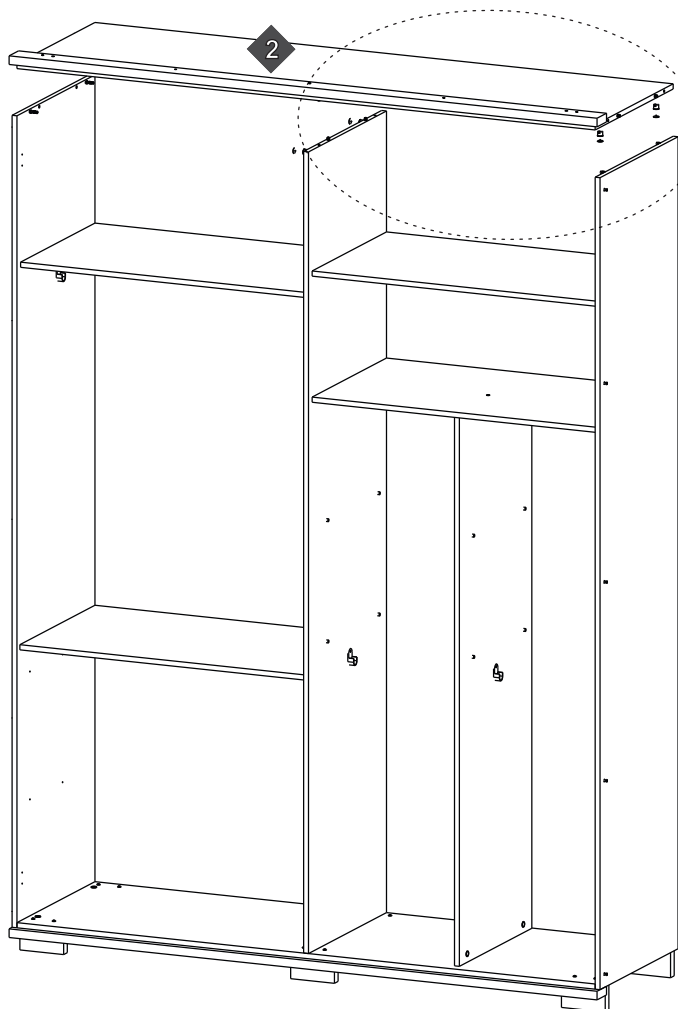
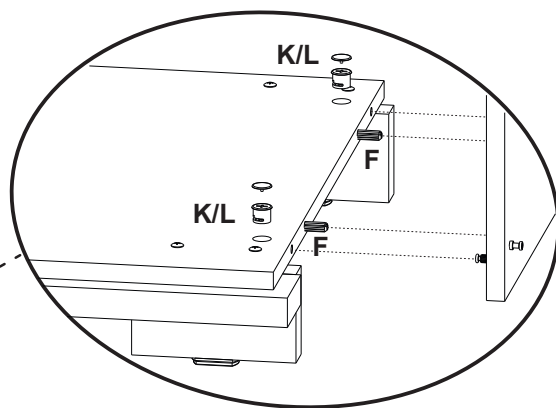
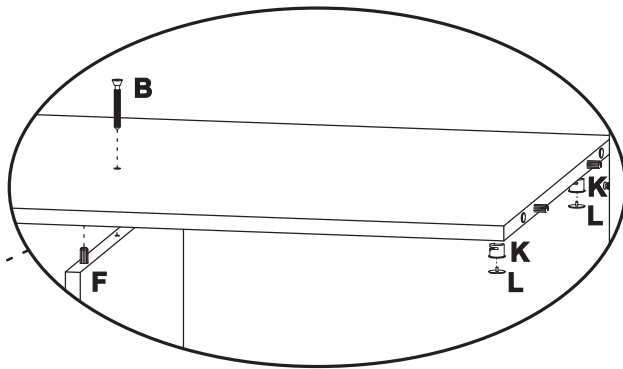
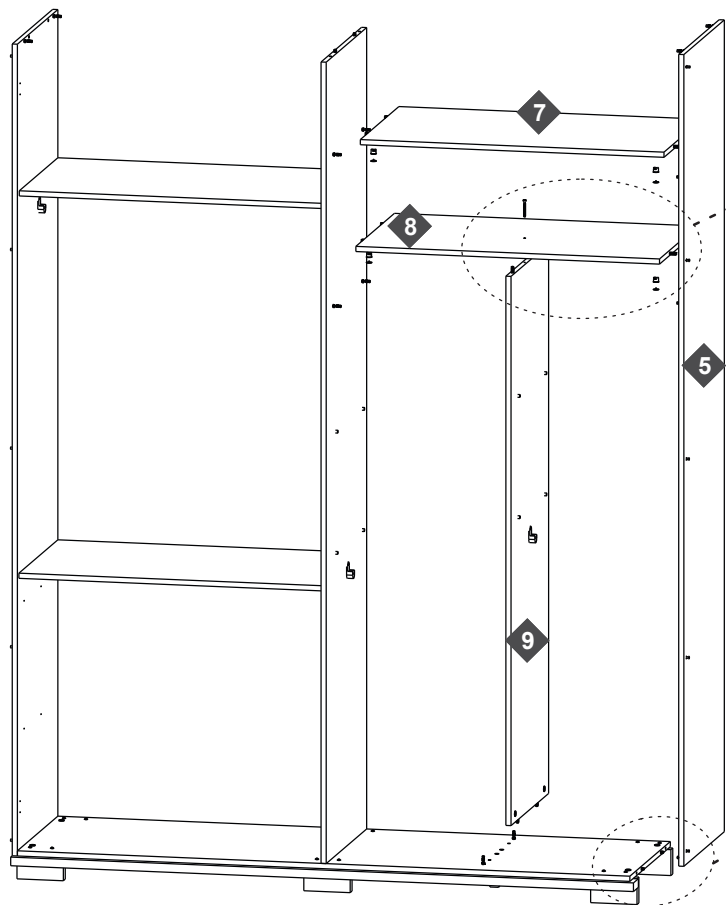

## INSTRUÇÕES

INSTRUCTIONS - INSTRUCCIONES

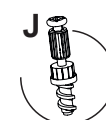
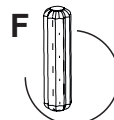
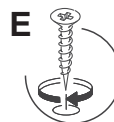
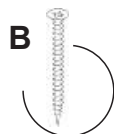

# MONTAGEM

ASSEMBLY - MONTAJE

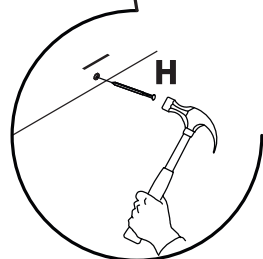
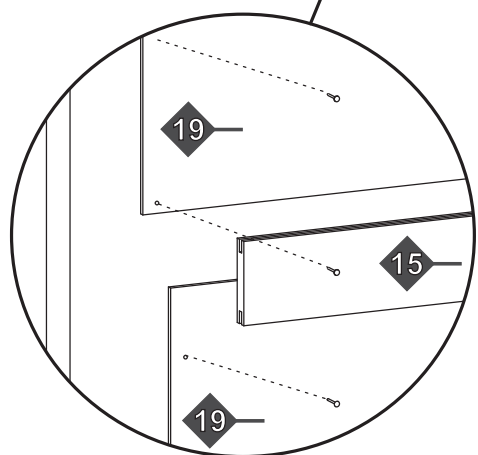
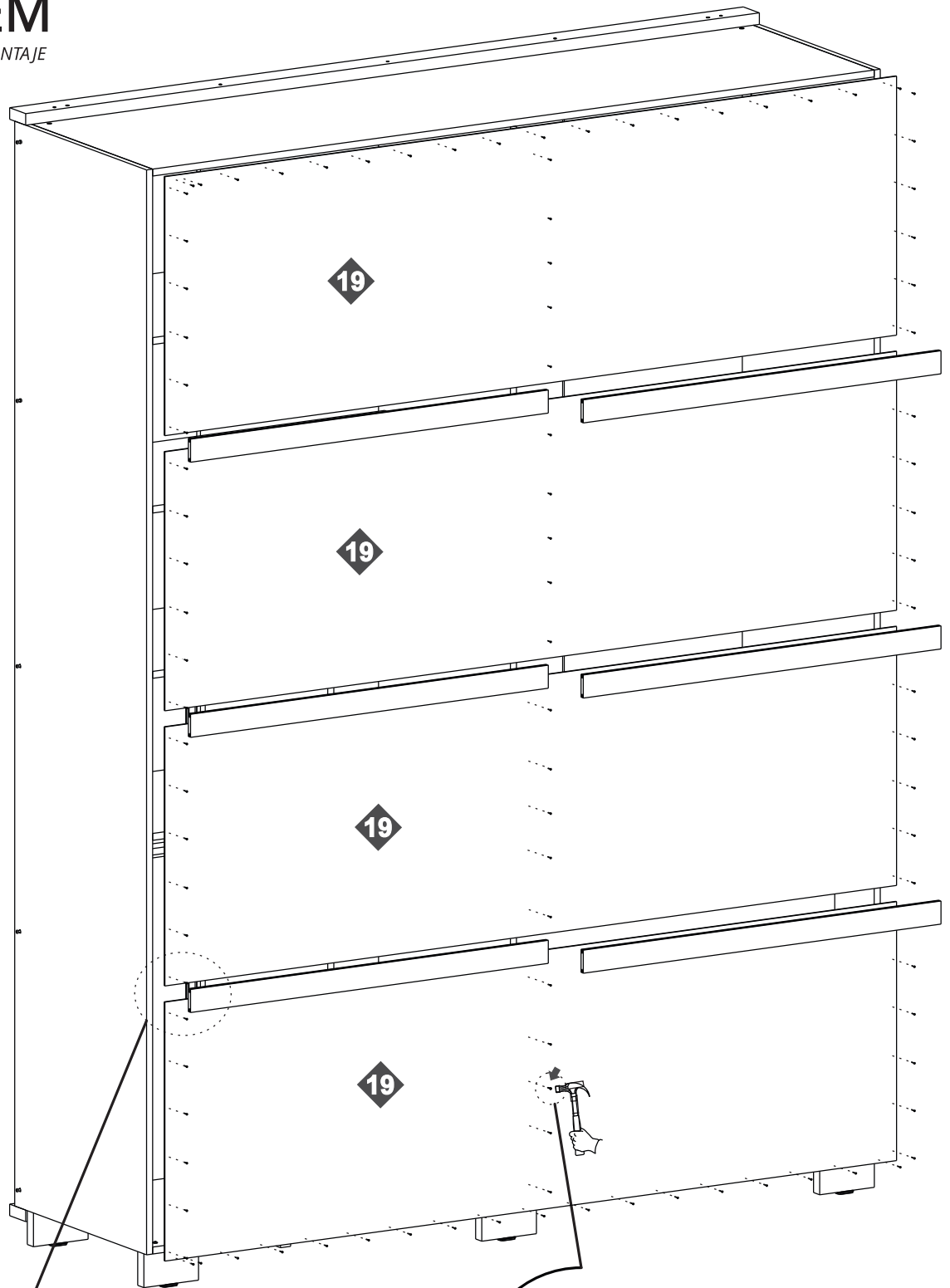

**INSTRUÇÕES**  
INSTRUCTIONS  
INSTRUCCIONES

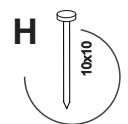

# MONTAGEM

ASSEMBLY - MONTAJE

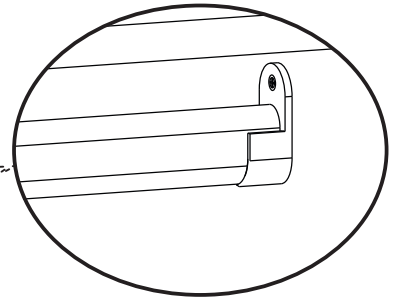
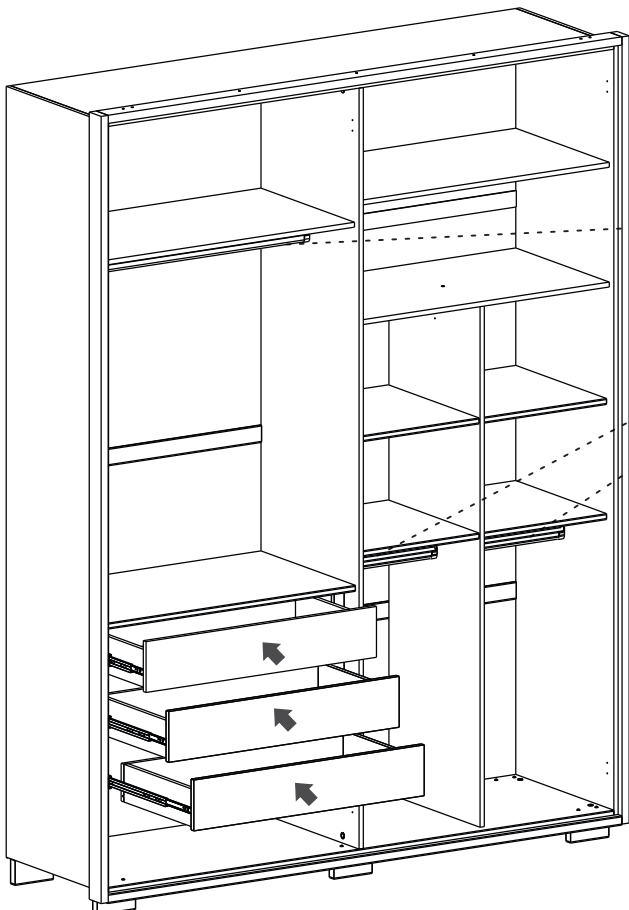
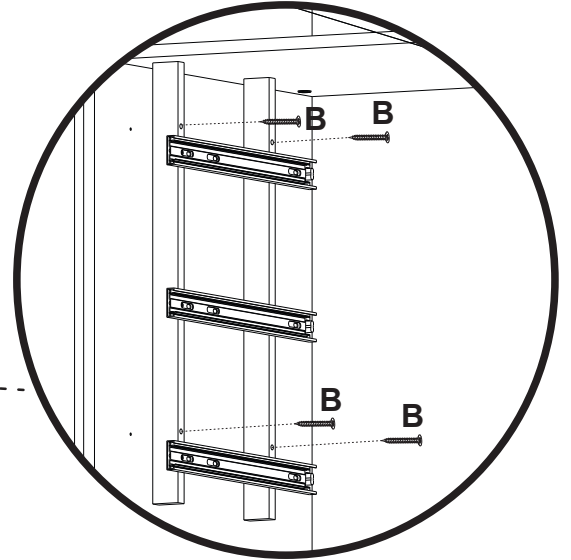
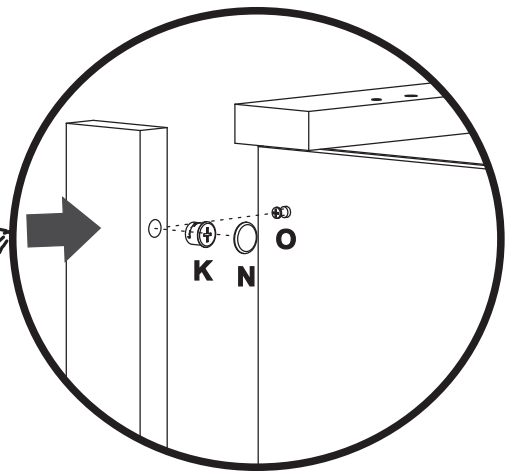
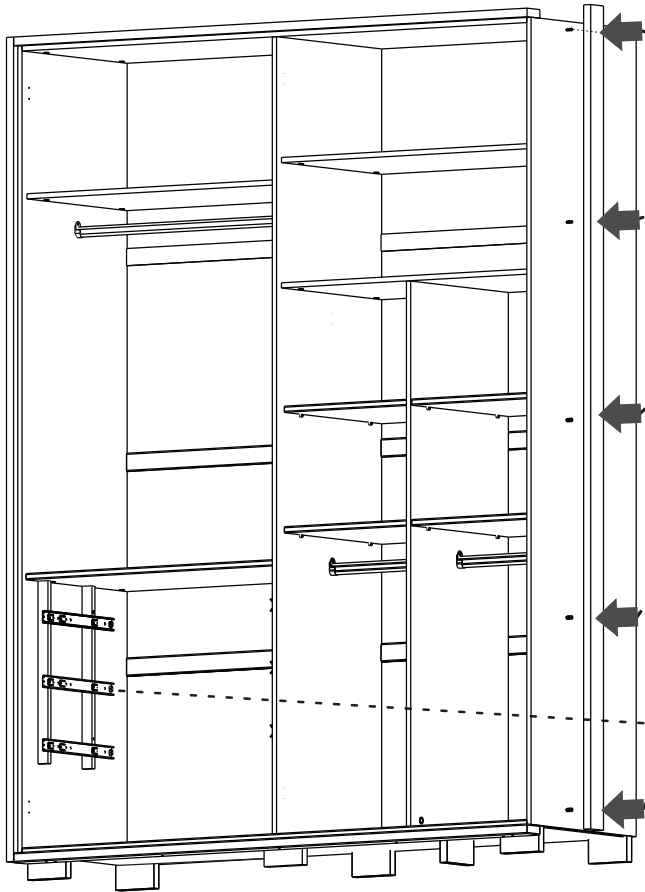

## ENCAIXAR O TUBO OBLONGO DO CABIDEIRO

\* FITTING THE OBLONG HANGER TUBE  
\* MONTAJE DEL TUBO DE SUSPENSIÓN ALARGADO

## ENCAIXAR AS GAVETAS

FITTING THE DRAWERS  
MONTAJE DE LOS CAJONES

## INSTRUÇÕES

INSTRUCTIONS - INSTRUCCIONES

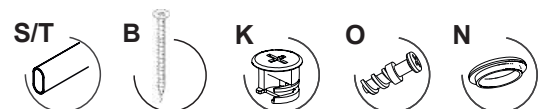

# MONTAGEM

ASSEMBLY - MONTAJE

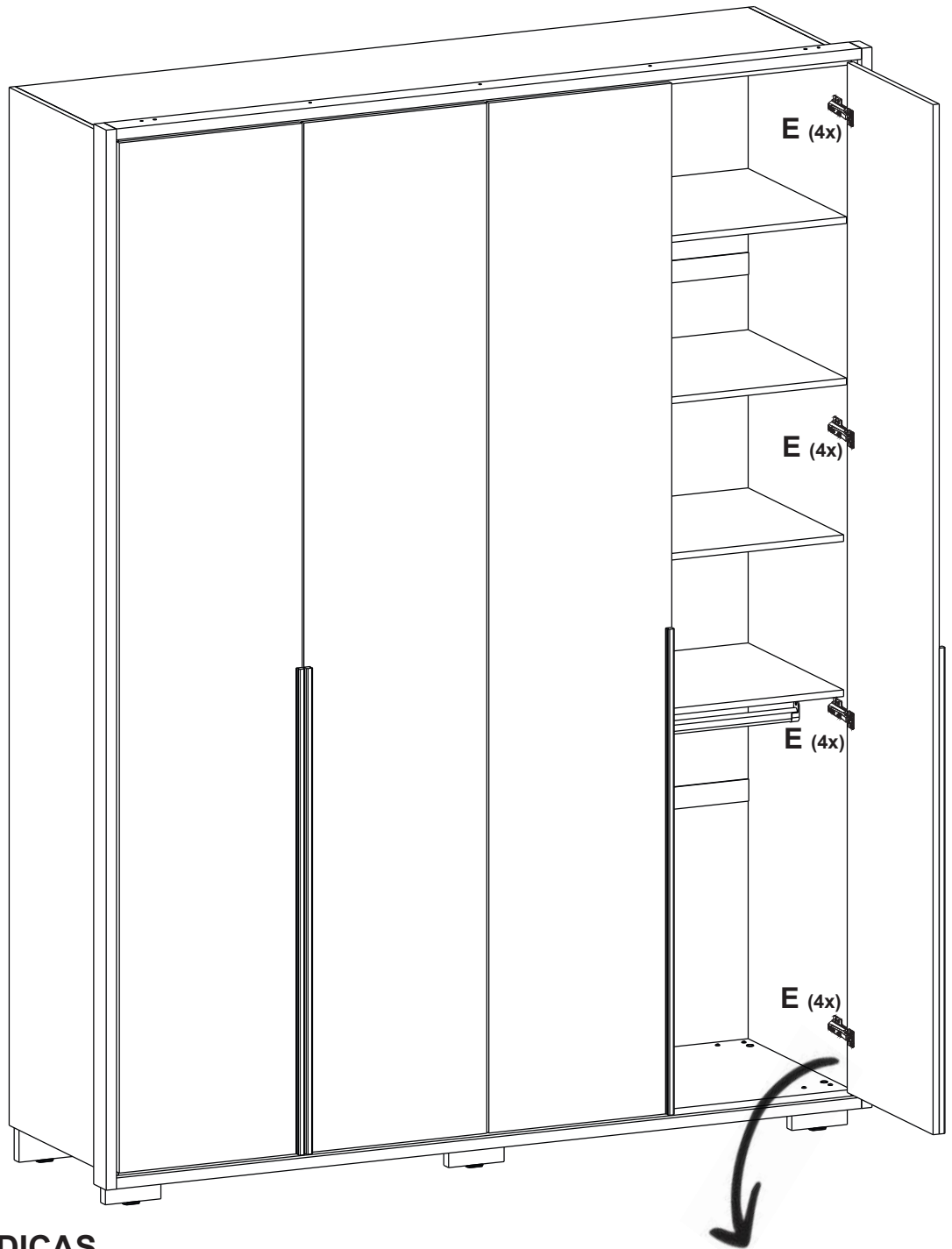

## FIXANDO AS DOBRADIÇAS

ATTACHING THE HINGES  
COLOCAR LAS BISAGRAS

- \* Fixar os parafusos no oblongo (1º) do calço;
- \* Regular as portas;
- \* Fixar os parafusos de reforço (2º) no calço.

\* Fix the screws on the oblong (1st) of the shim;  
\* Adjust the doors;  
\* Fix the screws reinforcement (2nd) in the wedge.

\* Fije los tornillos en el oblongo (1º) de la calza;  
\* Ajustar las puertas;  
\* Fijar los tornillos refuerzo (2º) en la cuña.

## INSTRUÇÕES

INSTRUCTIONS - INSTRUCCIONES

